

Uniprogramming

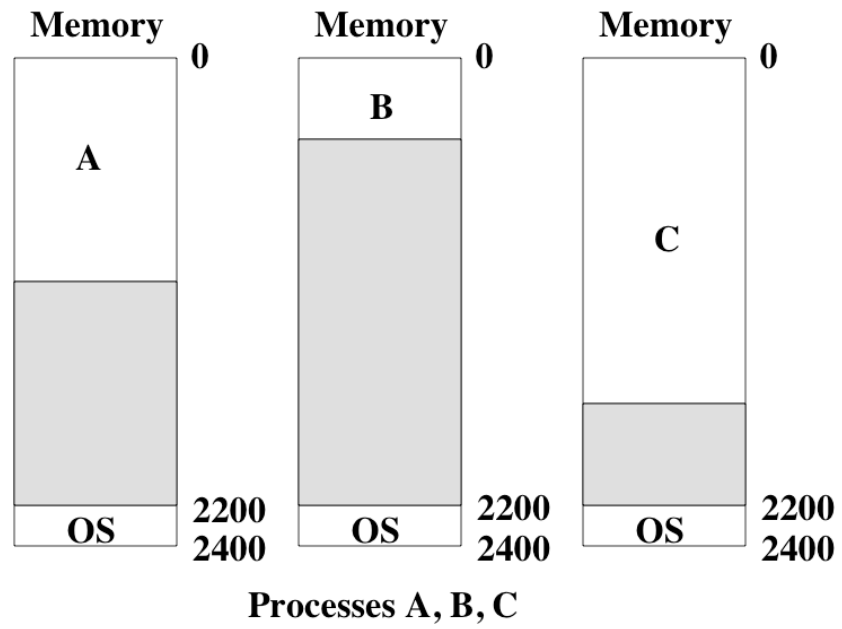

Relocation

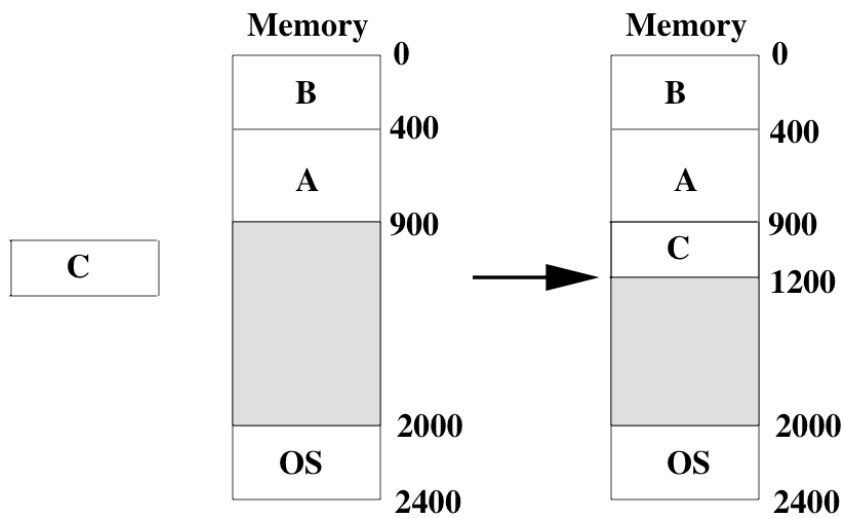

Dynamic Relocation

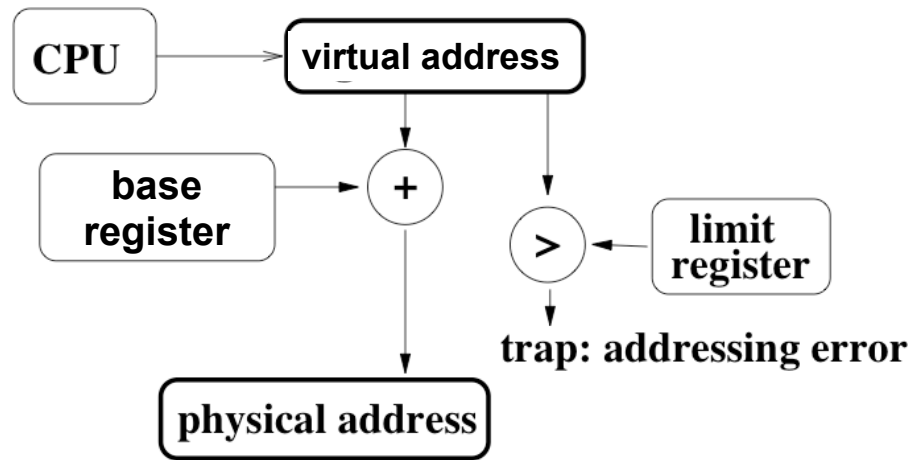

Address Spaces

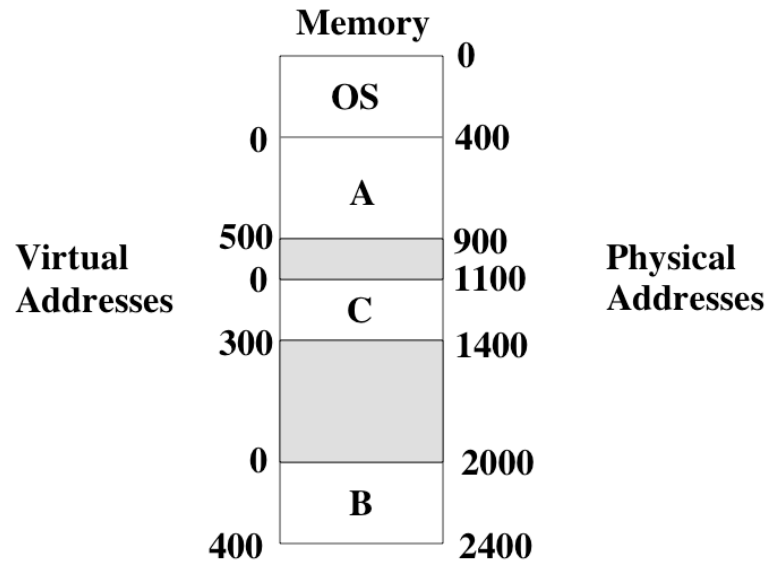

Memory Allocation

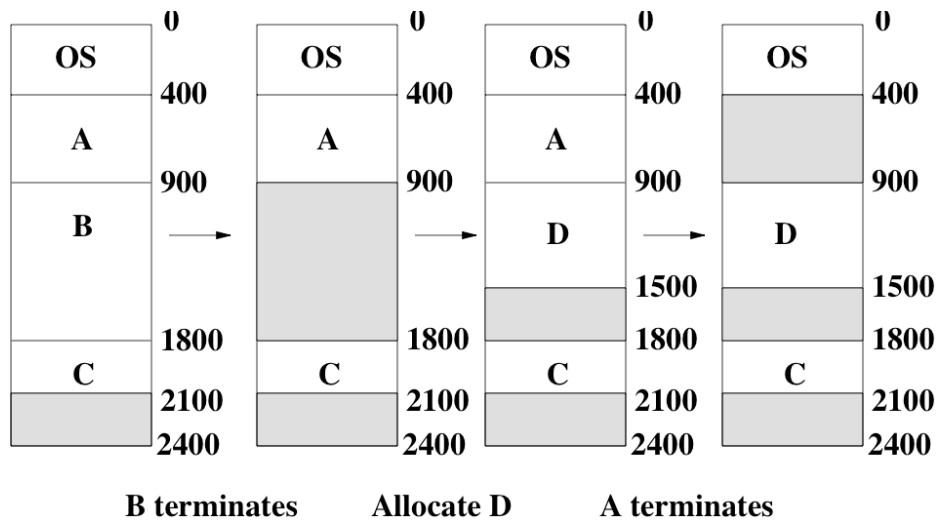

External Fragmentation

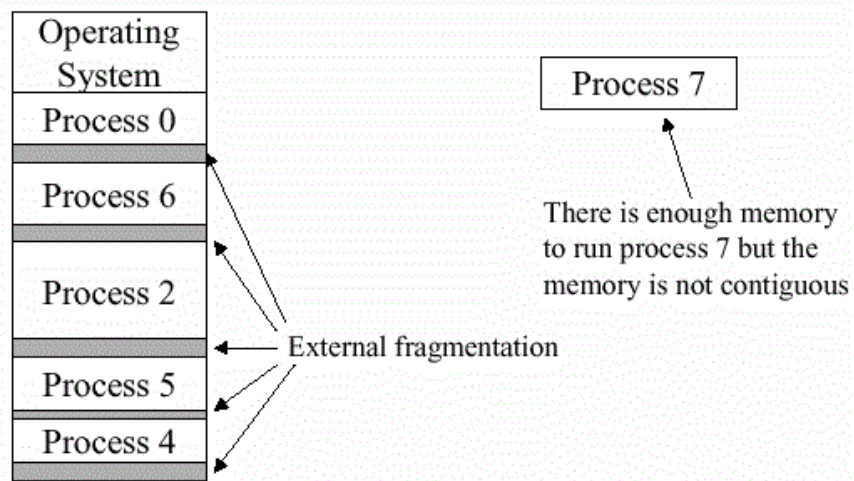

Internal Fragmentation

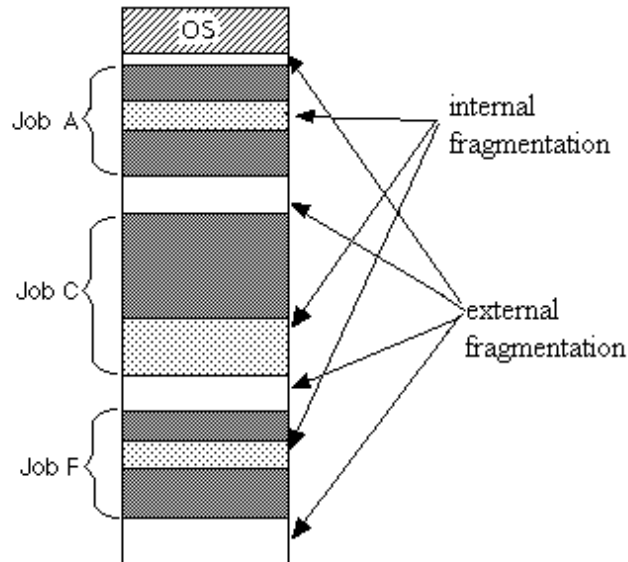

Compaction (defragmentation)

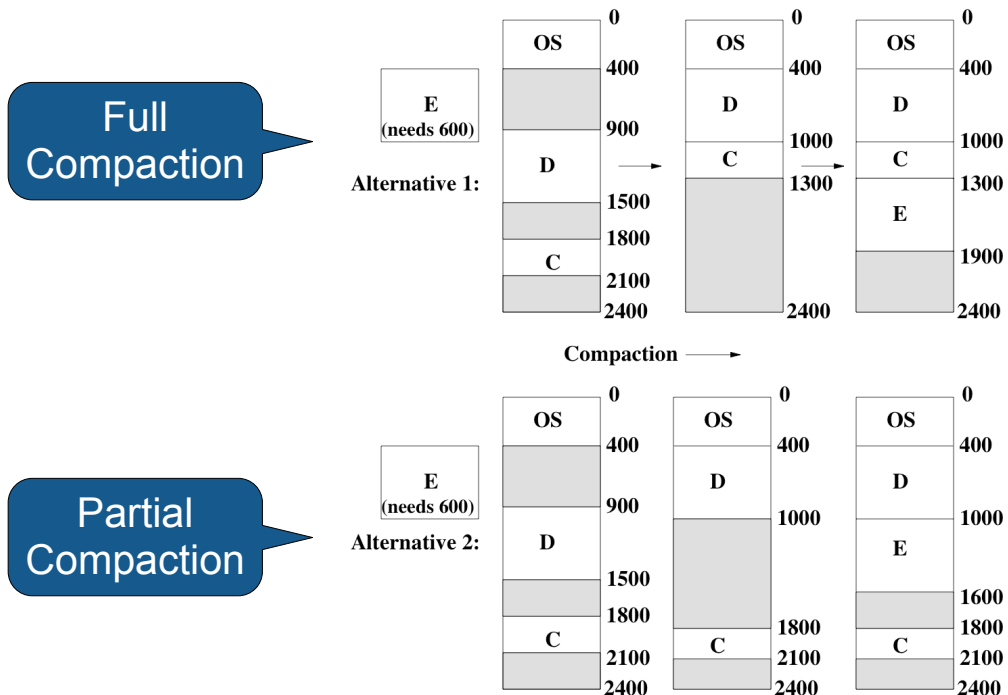

Memory Layout (Segments)

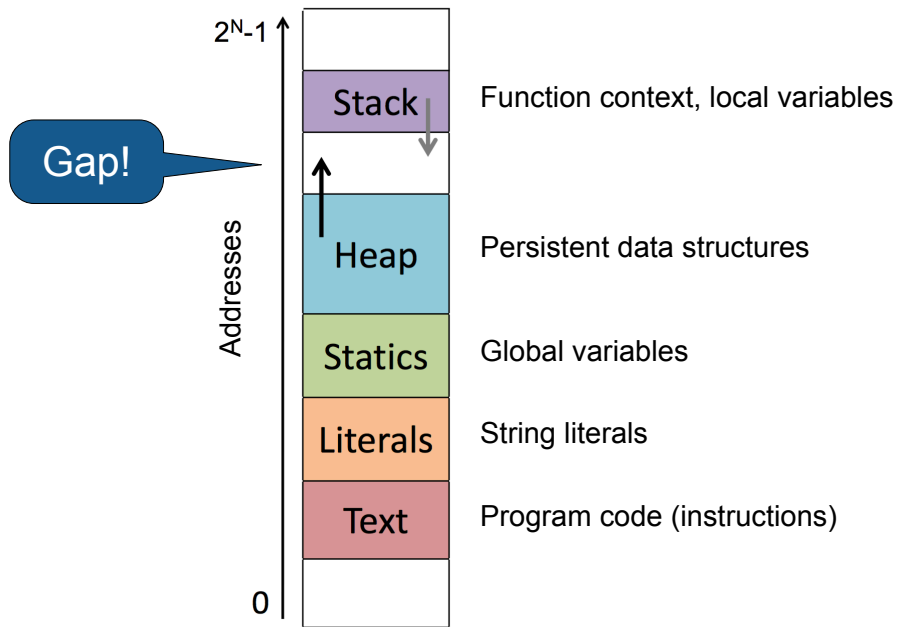

Segmentation

